



EBARA

CF1104UF

SLURRY PUMPS

MODEL SAL

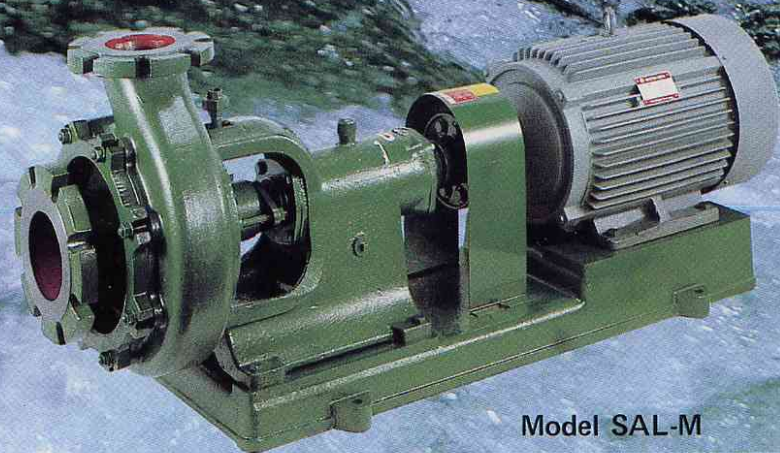

Model SAL-M



Model SAL-R

APPLICATIONS

● Chemical Industry



- Neutralizing agents (milk of lime)
- Filter press supply liquid (water with high mud concentration)
- Residual filter sediment (water with high mud concentration)
- Wet type dust collection (dust-impregnated water)
- Sediment disposal (drains)

● Metal/Mining



- Waste liquid (ore/mud-mixed water)
- Filter press supply liquid (water with high ore/mud concentration)
- Pit drains (earth/sand-mixed water)

● Oil Refining



- Waste disposal (noncorroded waste)
- Pit drains (water with soft mud)

● Cement/Concrete



- Milk of lime (lime-water mix)
- Used ready-mix concrete wash water (concrete/gravel-mixed water)
- Equipment drainage

● Paper & Pulp

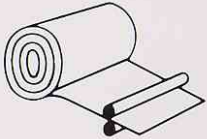

- Pulp treatment (max 4% concentration)
- Additives (clay-mixed water)
- Neutralizing liquid (milk of lime)
- Waste disposal (sediment-mixed water)

● Water Works & Drainage



- Sludge transport (water with high sludge concentration)
- Filter press supply sludge (water with high sludge concentration)
- Settling tank drainage (water with high sludge concentration)
- Concentrating tank drainage (sludge-mixed water)

● Foods



- Kitchen drains (filtrate)
- Waste liquid disposal

● Pottery Manufacturing



- Kaoline (Kaolin-mixed water)
- Grinding plants (residual water drainage)

● Sugar/Salt Manufacturing



- Used wash water (earth and sand-mixed water)
- Steamed and boiled liquid (molasses)

● Constructing/Quarrying

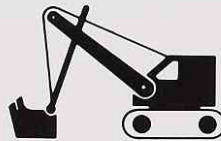

- Dredging (water mixed with sand and gravel)
- Mud water drainage (earth and sand mixed water)

● Steel Manufacturing & Refineries

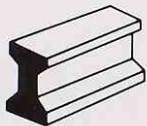

- Used coke cooling water (mixed with coke dust)
- Casting sand recovery (water mixed with sand)
- Conveyor pit drainage (water mixed with iron oxide)
- Residual settling tank liquid (water mixed with sludge)
- Dust collecting circulating liquid (dust mixed water)

● Motor car/Machinery Industries



- Paint disposal (paint mixed water)
- Used grinding liquid disposal (oil-liquid mixture with grinding sand dust)
- Used cutting oil disposal (oil mixed with chips)
- Wash water circulation (liquid mixed with chips, grindstone dust)

● Thermal Power Stations

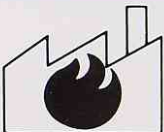

- Incinerator ash disposal (water mixed with ash, carbon)
- Dust disposal (dust-mixed water)

● Fisheries

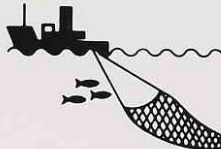

- Fish and shellfish disposal (boiled down liquid)
- Farming (sea water mixed sand)

FEATURES

1. No power overload

Specially designed impeller with a limit load feature is used so that there is never a power overload no matter what the head.

2. Low energy consumption and yet highly efficient.

Unique hydraulic design makes this pump more efficient than any other type. The initial rate of efficiency is sustained for reduced electrical power consumption.

3. Highly durable

A special, wear-resistant iron casting is used for both body and impeller.

4. Ample motor output allowance

The motor has ample power output allowance. It will operate without change of output with mixed solutions of 1.1 specific gravity.

5. Minimal gland packing leakage

Rear impeller vane ensures minimal leakage from durable gland packing.

6. Corrosion and wear-resistant materials

Both chrome iron casting and two-phase stainless steel are available. Interchangability makes a wide range of applications possible.

SPECIFICATIONS & ACCESSORIES

	Standard		Optional
	Model SAL-M	Model SAL-R	
Liquid Max. spherical solids (mm)	Slurry (Liquid containing particle matter) 40×32 SALE,F ϕ6 50×40 SALE,F ϕ7 50×40 SALG,H ϕ6 65×50 SALF,G,H ϕ8 80×65 SALF,G,H ϕ12		If specifications exceed those given at left, model URSD must be used.
Weight concentration Specific gravity of mixed solution Temperature	to 30% to 1.3 (Note: Will be greater than horsepower specified in catalog if over 1.1) 0~80°C (32~176°F)		
Max. suction press Suction head	to 1 kgf/cm ² up to Size 125×100—5m above Size 150×125—3m		
Installation	Indoors (SALE,F,G)	Indoor & Outdoor (SALH,J)	
Materials Casing Impeller Shaft Shaft sleeve	Low chrome cast iron High chrome cast iron 403 Stainless steel SAL-E,F,G Carbon steel SAL-H,J 420 Stainless steel		Two-phase stainless Two-phase stainless 304 Stainless steel 316 Stainless steel
Flange	JIS 10kgf/cm ²		
Construction Nozzle position Impeller type Stuffing box Bearing Lubrication	End suction, top discharge Semi-open type with rear vane Packing (External water sealing) Sealed ball SAL-E,F,G Ball & angular contact ball . SAL-H,J Grease SAL-E,F,G Oil bath SAL-H,J		Oil bath
Drive method	Motor direct drive	V belt drive.....SAL-H,J only	
Accessories	[With motor] Common base 1 Coupling 1 set Coupling guard 1 Anchor bolts 1 set	[With motor] Common base 1 V pulley 1 set V belt 1 set Belt cover 1 Anchor bolts 1 set	Companion flanges Self priming tank Foot valve Priming funnel & valve

SECTIONAL VIEW

Model SAL-E, F, G

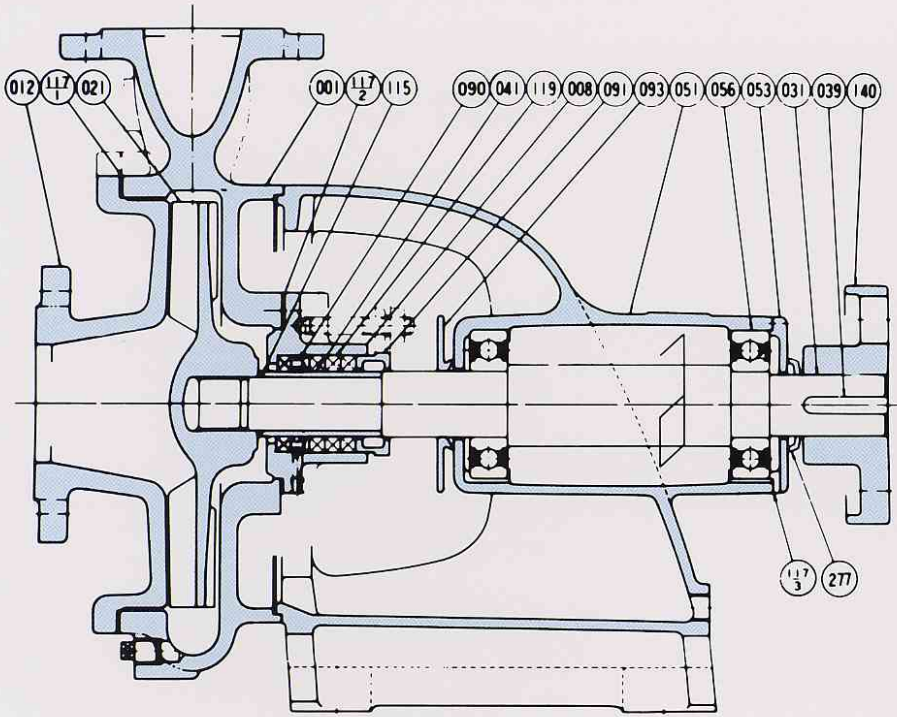

PART No.	PART NAME	No. for 1 Unit
001	CASING	1
008	STUFFING BOX	1
012	SUCTION COVER	1
021	IMPELLER	1
031	SHAFT	1
039	KEY	1
041	SHAFT SLEEVE	1
051	BEARING HOUSING	1
053	BEARING COVER	1
056	BALL BEARING	2
090	LANTERN RING	1
091	GLAND	1
093	DEFLECTOR	1
115	"O" RING	1
117-1	GASKET	1
117-2	GASKET	1
117-3	GASKET	1
119	PACKING	4
140	COUPLING	1 SET
277	V RING	1

Model SAL-H, J

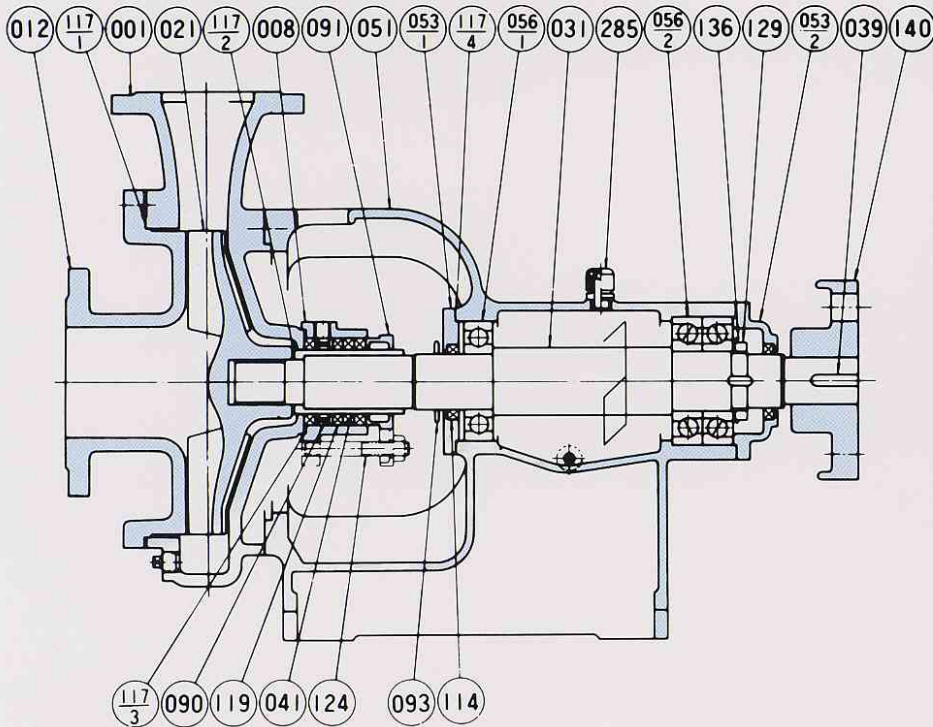

PART No.	PART NAME	No. for 1 Unit
001	CASING	1
008	STUFFING BOX	1
012	SUCTION COVER	1
021	IMPELLER	1
031	SHAFT	1
039	KEY	1
041	SHAFT SLEEVE	1
051	BEARING HOUSING	1
053-1	BEARING COVER	1
053-2	BEARING COVER	1
056-1	BALL BEARING	1
056-2	BALL BEARING	1 SET
090	LANTERN RING	1
091	GLAND	1
093	DEFLECTOR	1
114	OIL SEAL	2
117-1	GASKET	1
117-2	GASKET	1
117-3	GASKET	1
117-4	GASKET	2
119	PACKING	4
124	GLAND BOLT	2
129	NUT	1
136	WASHER	1
140	COUPLING	1 SET
285	AIR VENT	1

ABOUT WEAR AND CORROSION RESISTANCE

Wear resistance

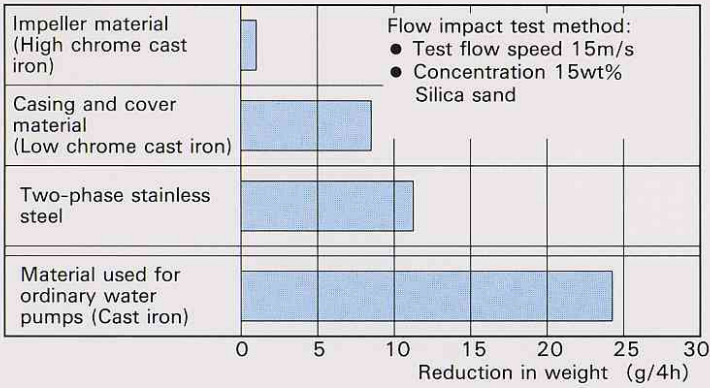

- The impellers, which are subject to the greatest possibility of wear, are of tough high chrome cast iron about 20 times as wear resistant as ordinary cast iron.
- The casing, which is subject to less possibility of wear, is of less expensive low chrome cast iron with three to five times the wear resistance of ordinary cast iron.

Corrosion resistance

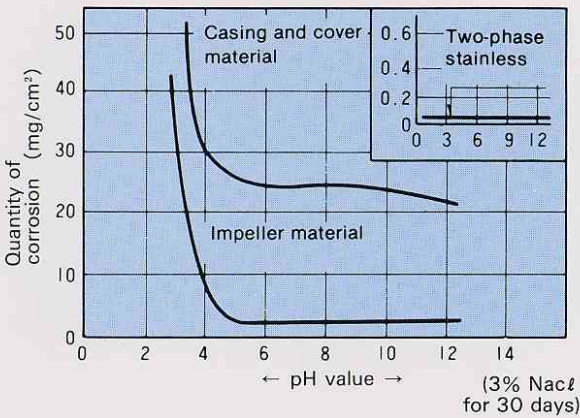

TWO-PHASE STAINLESS STEEL

18-8 system stainless steel now widely favored as an anticorrosive material is vulnerable to an atmosphere with chlorine ions. To cope with this, EBARA has developed two-phase stainless steel which is resistant to stress corrosion cracks, for use especially in chemical plants, ocean development equipment and food industrial plants.

Two-phase stainless steel is composed of austenite with a 40 to 60% ferrite content. The principle features of each—the superior corrosion resistance of austenite and the hardness and strength of ferrite—have been skillfully combined. This two-phase stainless steel can be used without the problems of conventional steels such as wear, corrosion, and cracking and is especially suited for use with sea water.

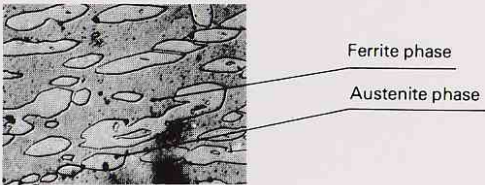

(Example of Corrosion Resistance)

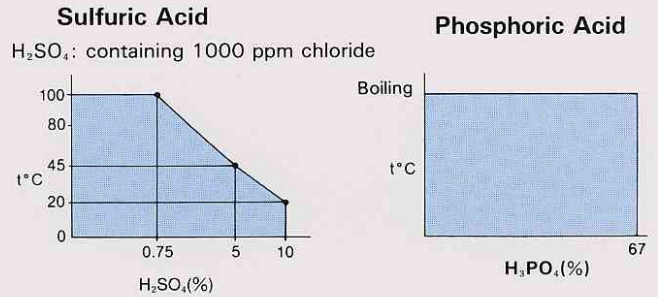

Hydrochloric Acid

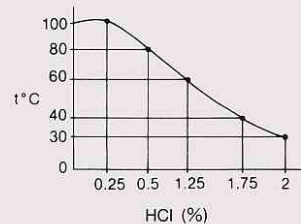

- Note:
1. Shaded portion indicates approved limits.
 2. Two-phase stainless steel corrosion resistance is nearly the same as that of SCS-16 and its wear resistance is nearly the same as low-chrome cast iron.

Corrosion Resistance Comparison

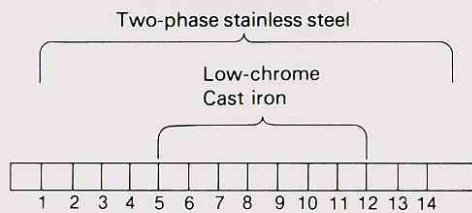

pH value with which these materials can be used

SELECTION CHARTS

Model SAL-M(Motor direct drive)

50Hz [Synchronous speed: 1500min⁻¹]

[Shaded portion synchronous speed: 1000min⁻¹]

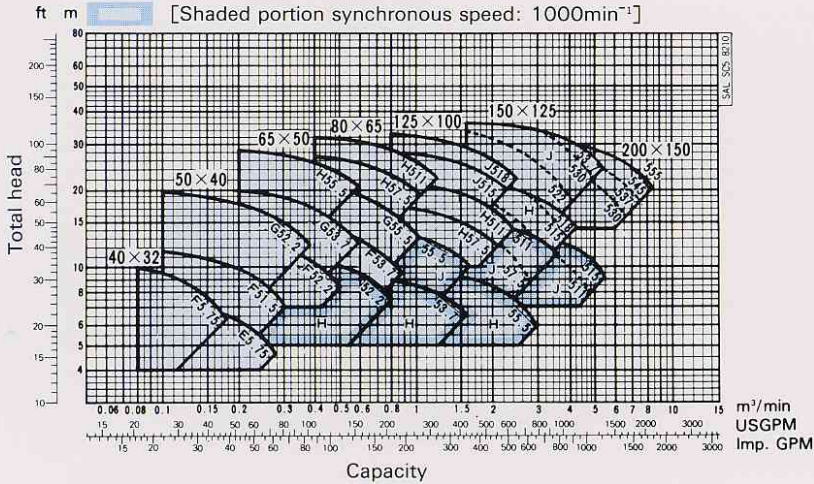

Note:

1. Impeller measurements will vary for 150x125 and 200x150 according to capacities and heads used. Indicate capacities and heads.
2. Output indicated in the chart is in relation to a 1.1 specific gravity. If specific gravity exceeds 1.1, output must be raised one level.

Symbols

50x40 SALG 5 2.2

- Motor output kW
- Frequency 50 Hz:5 60 Hz:6
- Model
- Discharge size(mm)
- Suction size(mm)

60Hz [Synchronous speed: 1800min⁻¹]

[Shaded portion synchronous speed: 1200min⁻¹]

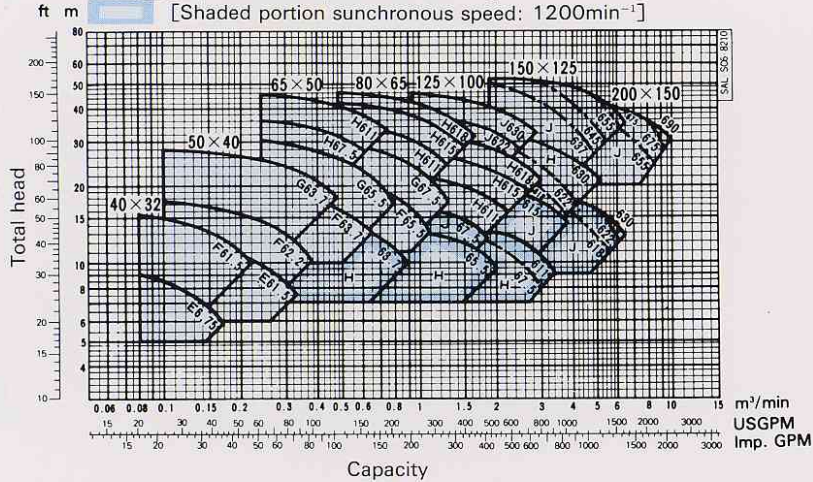

50 Hz

Size	Model	Pole	Motor kW	Capacity, m ³ /min	T.H. m	Capacity, m ³ /min	T.H. m	Capacity, m ³ /min	T.H. m
40x32	SALF5.75	4	0.75	0.08	11.5	0.13	10	0.18	7.7
	SALG5.75		0.75	0.17	7.5	—	—	0.26	5.5
50x40	SALF51.5	4	1.5	0.1	13.5	0.21	11.7	0.32	9
	SALG52.2		2.2	0.1	20	0.21	17.3	0.33	13
65x50	SALF52.2	4	2.2	0.32	12.5	—	—	0.5	9.5
	SALG53.7		3.7	0.2	20.5	0.4	17.5	0.57	13
	SALH55.5		5.5	0.2	29	0.4	25.5	0.6	21
80x65	SALH52.2	6	2.2	0.52	10	—	—	0.8	7.5
	SALF53.7	4	3.7	0.55	13.5	0.7	11.5	0.85	10
	SALG55.5		5.5	0.4	21.5	0.7	18	1.0	13.5
	SALH57.5		7.5	0.4	27	0.7	24	1.05	19.5
125x100	SALH51	4	11	0.4	32	0.8	29	1.25	23
	SALH53.7	6	3.7	0.85	8.8	—	—	1.6	6.5
	SALJ55.5	6	5.5	1.0	13	—	—	1.65	9.8
	SALH57.5	4	7.5	0.8	17.2	1.5	15	2.1	12
	SALH551	4	11	1.05	20.5	1.8	18	2.5	14
150x125	SALH515	4	15	0.9	28	1.7	24.5	2.3	20
	SALJ518	4	18.5	0.9	33	1.6	29.5	2.55	22

60 Hz

Size	Model	Pole	Motor kW	Capacity, m ³ /min	T.H. m	Capacity, m ³ /min	T.H. m	Capacity, m ³ /min	T.H. m
40x32	SALF6.75	4	0.75	0.08	9.3	—	—	0.16	6.8
	SALF61.5		1.5	0.08	18	0.14	15.8	0.2	13
50x40	SALF61.5	4	1.5	0.2	11	—	—	0.32	7.6
	SALF62.2		2.2	0.1	20	0.25	17.3	0.4	13
65x50	SALG63.7	4	3.7	0.1	28	0.25	23.3	0.4	17.6
	SALF63.7	4	3.7	0.4	18	—	—	0.55	15
	SALG65.5		5.5	0.25	31	0.45	27.5	0.65	22
80x65	SALH67.5	4	7.5	0.28	35.5	0.45	32	0.6	27
	SALH611		11	0.28	45	0.5	40	0.75	33
	SALH63.7	6	3.7	0.55	13.5	—	—	0.9	10
125x100	SALF65.5	4	5.5	0.65	19.5	0.85	16.5	1.05	13.5
	SALG67.5		7.5	0.45	29	0.85	24	1.2	18
	SALH611	4	11	0.75	32	1.0	29	1.25	24
	SALH615		15	0.48	42	0.9	38	1.5	28
	SALH618.5		18.5	0.48	47	1.0	42	1.65	31
150x125	SALH65.5	6	5.5	1.1	12.5	—	—	2.0	9.4
	SALJ67.5	6	7.5	1.2	16	—	—	1.85	12.5
	SALH611	4	11	1.1	21	1.6	19	2.2	16
	SALH115		15	1.35	26	2.0	23	2.65	19
	SALJ618	4	18.5	1.55	29.5	2.2	26.5	3.0	21
	SALJ622		22	1.4	36	—	—	2.5	27.5
SALJ630	4	30	0.96	46.5	1.9	41	2.95	31.5	

Pumps with 150 x 125 and 200 x 150 diameters must be matched to capacities and heads used. Indicate what principal items will be used.

SELECTION CHARTS

Model SAL-R (V belt drive)

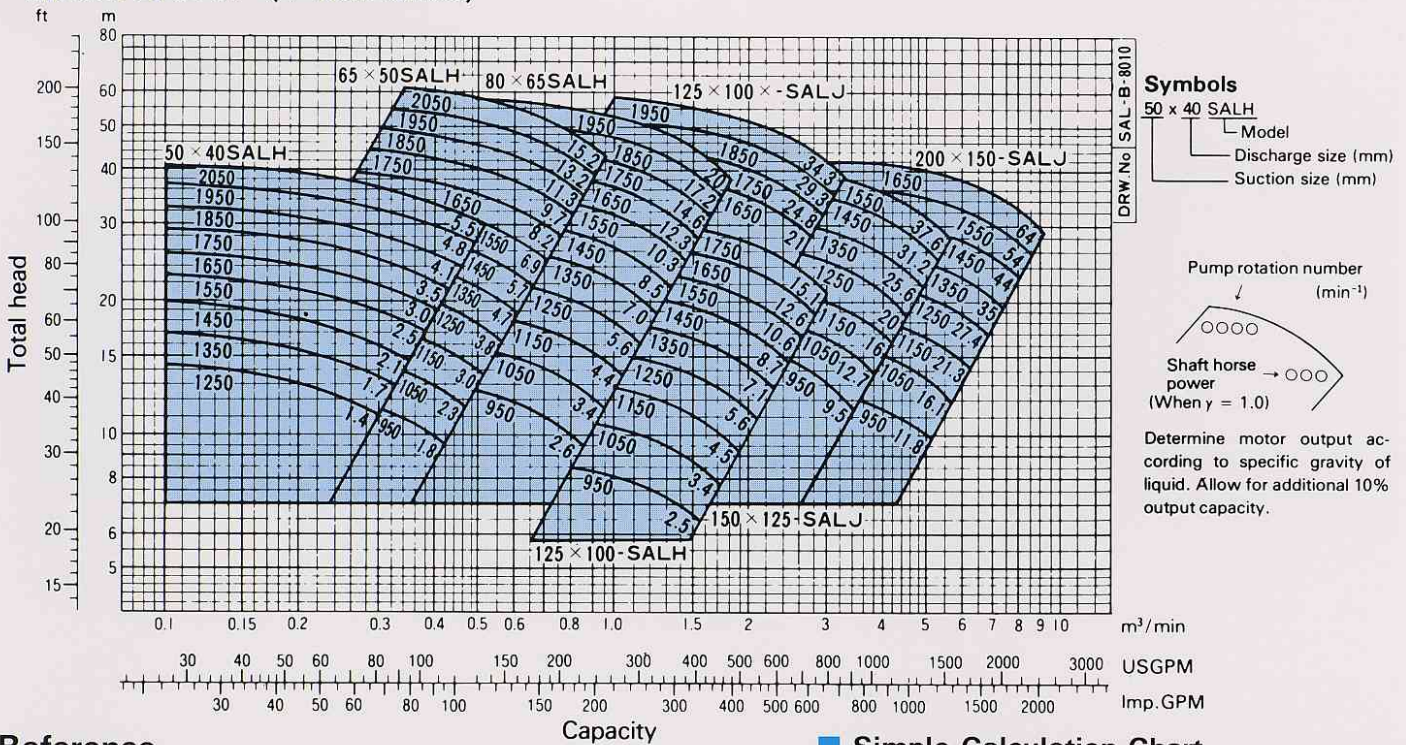

Reference

Finding specific gravity of mixed solution specific gravity of solids

Material	True specific gravity σ	Material	True specific gravity σ
Anthracite	1.5	Gypsum	2.3
Bauxite	2.5	Hematite	5.2
Brick	2.0-5.9	Iron sand ore	2.7-(3.0)
Calcium oxide	3.4	Lead	11.3
Cement	2.7-3.2**	Limestone	2.7-3.0
Charcoal	1.4-1.9	Limonite	3.7
Chrome iron ore	4.3	Magnetite	5.2
Clay	2.5-2.9	Marble	2.68
Coal	1.3-(2.0)	Paper fiber	1.54
Concrete	2.3	Quartz and rock crystal	2.65-2.7
Copper pyrite	4.2	Sandstone	2.05
Cuprite	6.0	Sand (grain size 0.05-2mm)	2.61-2.8
Cupreous ore	3.5	Silt	2.7
Cupreous slag	2.5-2.65	Soda lime glass	2.5
Diatomaceous earth	1.92	Saliceous terra alba	2.17
Dolomite	2.6-2.9	Sulphide	3.3
Fly ash	2.04	Sulphur	2.1
Galena	7.5	Tin stone	6.8
Glass	2.2-6.0	Tuff	1.5-2.0
Granite	2.65	Turf	1.26-1.46
Gravel	2.61-2.68*		

*Average 2.65 mm
 **Average 3.0 mm

Simple Calculation Chart

(for calculating compound specific gravity on basis of specific gravity of solids and weight concentration.)

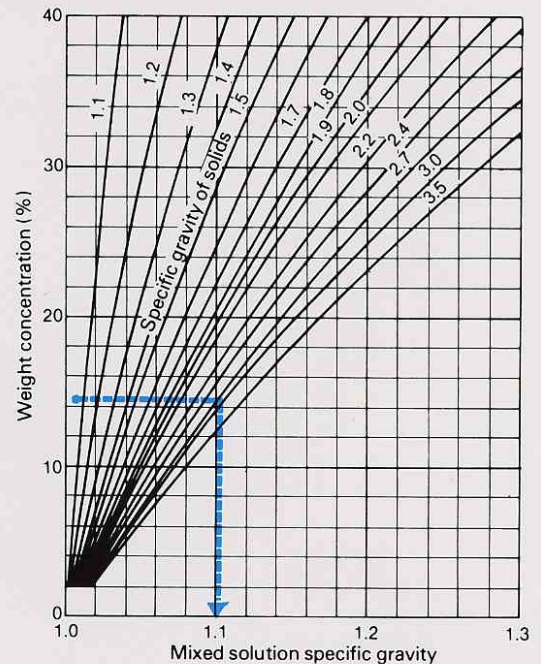

(Example)

The liquid is silt and has a weight concentration of 14.5%. You want to find specific gravity of the mixed solution.

- Determine specific gravity of silt by referring to chart listing specific gravity of solids.
- Using the Simple Calculation Chart at left, draw a horizontal line at the point where weight concentration is 14.5%. Draw a vertical line down from the point where the horizontal line intersects with the 2.7 specific gravity curve.
- This gives a mixed solution specific gravity of 1.1.

DIMENSIONS

Model SAL-M (Motor direct drive) 50Hz

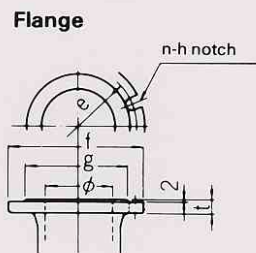
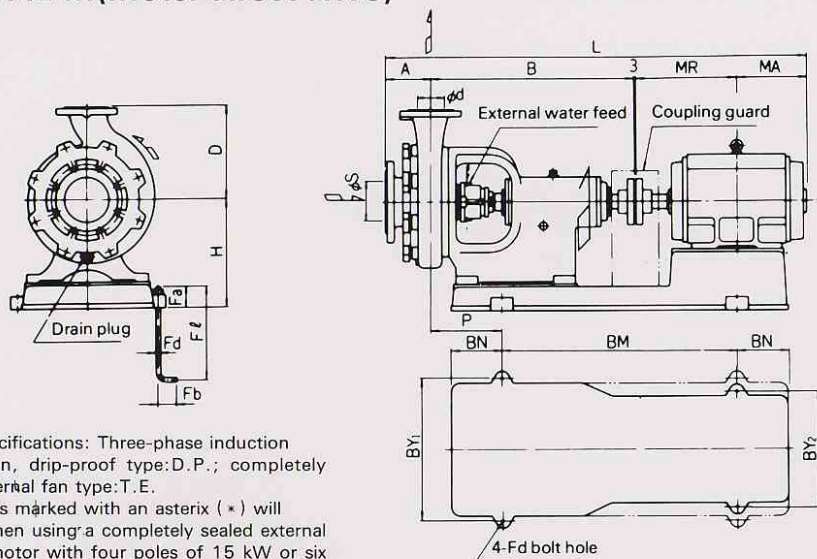

Unit: mm

Size ϕ	g	e	F	t	n	h
32	80	100	135	18	4	19
40	85	105	140	18	4	19
50	100	120	155	20	4	19
65	120	140	175	22	4	19
80	130	150	185	22	8	19
100	155	175	210	24	8	19
125	185	210	250	24	8	24
150	215	240	280	26	8	24
200	265	290	330	26	12	24

External water feed	EFG type 1/4B 2~3ℓ/min × 1kgf/cm ² (98.1kPa)
	HJ type 3/8B 3~5ℓ/min × 2.0kgf/cm ² (196.1kPa)

- Note:
- Motor specifications: Three-phase induction motor; open, drip-proof type: D.P.; completely sealed external fan type: T.E.
 - Dimensions marked with an asterisk (*) will change when using a completely sealed external fan type motor with four poles of 15 kW or six poles of less than 11 kW.
 - The pump must never be allowed to rotate in reverse. Confirm test in operation of motor only that rotation direction is correct.

 4 pole motor
 6 pole motor
 Unit: mm

Size ϕ S × ϕ d	Model	Motor output kW	Pump							Motor				Corron base				Anchor bolt				Weight (Mass) kg
			A	B	D	H	L*	P	Frame No.	Type	MA*	MR	BM	BN	BY ₁	BY ₂	Fd	Fℓ	Fa	Fd		
40X32	40x 32SALF5.75	0.75	80	355	180	225	675	160	80	D.P.	97	140	340	120	304	244	M10	200	40	40	70	
	50x 40SALE5.75	0.75	100	355	180	225	695	160	80	D.P.	97	140	340	120	304	244	M10	200	40	40	70	
	50x 40SALF51.5	1.5	100	355	180	225	741.5	160	90L	D.P.	115	168.5	340	120	304	244	M10	200	40	40	78	
50X40	50x 40SALG52.2	2.2	100	375	225	255	791	185	100L	D.P.	130	183	360	140	350	304	M12	250	55	50	113	
	65x 50SALF52.2	2.2	100	460	225	290	876	217.5	100L	D.P.	130	183	380	180	410	304	M12	250	55	50	144	
	65x 50SALG53.7	3.7	100	460	225	290	900	217.5	112M	D.P.	137	200	380	180	410	304	M12	250	55	50	152	
65X50	65x 50SALH55.5	5.5	110	545	280	285	1050	215	132S	D.P.	153	239	680	170	390	390	M12	250	55	50	227	
	80x 65SALF53.7	3.7	100	460	250	290	900	217.5	112M	D.P.	137	200	380	180	410	304	M12	250	55	50	150	
	80x 65SALG55.5	5.5	100	460	250	290	955	217.5	132S	D.P.	153	239	540	180	410	410	M12	250	55	50	195	
	80x 65SALH57.5	7.5	120	550	280	285	1104	220	132M	D.P.	173	258	680	170	390	390	M12	250	55	50	246	
	80x 65SALH511	11	120	550	280	285	1214	220	160M	D.P.	218	323	680	170	390	390	M12	250	55	50	276	
80X65	80x 65SALH52.2	2.2	120	550	280	275	1010	205	112M	D.P.	137	200	500	155	390	310	M12	250	55	50	209	
	125x 100SALH57.5	7.5	150	565	280	285	1149	235	132M	D.P.	173	258	680	170	390	390	M12	250	55	50	246	
	125x 100SALH511	11	150	565	280	285	1259	235	160M	D.P.	218	323	680	170	390	390	M12	250	55	50	276	
	125x 100SALH53.7	3.7	150	565	280	285	1110	235	132S	D.P.	153	239	680	170	390	390	M12	250	55	50	237	
	125x 100SALJ515	15	155	695	315	370	1436	240	160L	D.P.	238	345	800	175	480	390	M16	315	70	63	397	
	125x 100SALJ518	18.5	155	695	315	380	1507	265	180M	T.E.	302.5	351.5	860	200	490	490	M16	315	70	63	460	
	125x 100SALJ55.5	5.5	155	695	315	370	1284	240	132M	D.P.	173	258	800	175	480	390	M16	315	70	63	347	
	150x 125SALH511	11	180	355	355	370	1434	255	160M	D.P.	218	323	800	175	480	390	M16	315	70	63	431	
	150x 125SALH515	15	180	710	355	370	1476	255	160L	D.P.	238	345	800	175	480	390	M16	315	70	63	452	
	150X125	150x 125SALH518.5	18.5	180	710	355	370	1476	255	160L	D.P.	238	345	800	175	480	390	M16	315	70	63	466
150x 125SALH55.5		5.5	180	710	355	370	1324	255	132M	D.P.	173	258	800	175	480	390	M16	315	70	63	407	
150x 125SALJ522		22	180	710	355	380	1481	280	180M	D.P.	236.5	351.5	860	200	490	490	M16	315	70	63	501	
150x 125SALJ530		30	180	710	355	380	1519	280	180L	T.E.	321.5	370.5	860	200	490	490	M16	315	70	63	546	
150x 125SALJ537		37	180	710	355	380	1519	280	180L	D.P.	255.5	370.5	860	200	490	490	M16	315	70	63	526	
150x 125SALJ57.5		7.5	180	710	355	370	1703	300	200L	T.E.	364.5	395.5	860	200	490	490	M16	315	70	63	611	
150x 125SALJ511		11	180	710	355	370	1476	255	160L	D.P.	238	345	800	175	480	390	M16	315	70	63	470	
200X150		200x 150SALJ530	30	220	895	400	460	1744	350	180L	D.P.	255.5	370.5	960	220	640	500	M16	315	70	63	733
		200x 150SALJ537	37	220	895	400	460	1878	350	200L	T.E.	364.5	395.5	960	220	640	500	M16	315	70	63	818
		200x 150SALJ545	45	220	895	400	460	1824	350	200M	D.P.	261.5	406.5	960	220	640	500	M16	315	70	63	773
	200x 150SALJ555	55	220	895	400	460	1928	370	225S	T.E.	378	432	1040	240	640	500	M20	400	85	80	893	
	200x 150SALJ511	11	220	895	400	460	1824	350	200L	D.P.	280.5	425.5	960	220	640	500	M16	315	70	63	798	
	200x 150SALJ515	15	220	895	400	460	1953	370	225M	T.E.	390.5	444.5	1040	240	640	500	M20	400	85	80	923	
	200x 150SALJ511	11	220	895	400	460	1862	370	225M	D.P.	299.5	444.5	1040	240	640	500	M20	400	85	80	878	
	200x 150SALJ511	11	220	895	400	460	2113	370	250M	T.E.	512.5	482.5	1040	240	640	500	M20	400	85	80	1103	
	200x 150SALJ515	15	220	895	400	460	1706	350	160L	D.P.	238	345	960	220	640	500	M16	315	70	63	683	
200x 150SALJ515	15	220	895	400	460	1810	350	180M	D.P.	236.5	351.5	960	220	640	500	M16	315	70	63	718		
200x 150SALJ515	15	220	895	400	460	1810	350	180L	T.E.	321.5	370.5	960	220	640	500	M16	315	70	63	743		

DIMENSIONS

Model SAL-R(V belt drive)

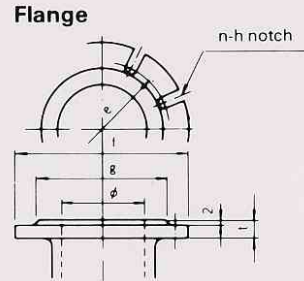
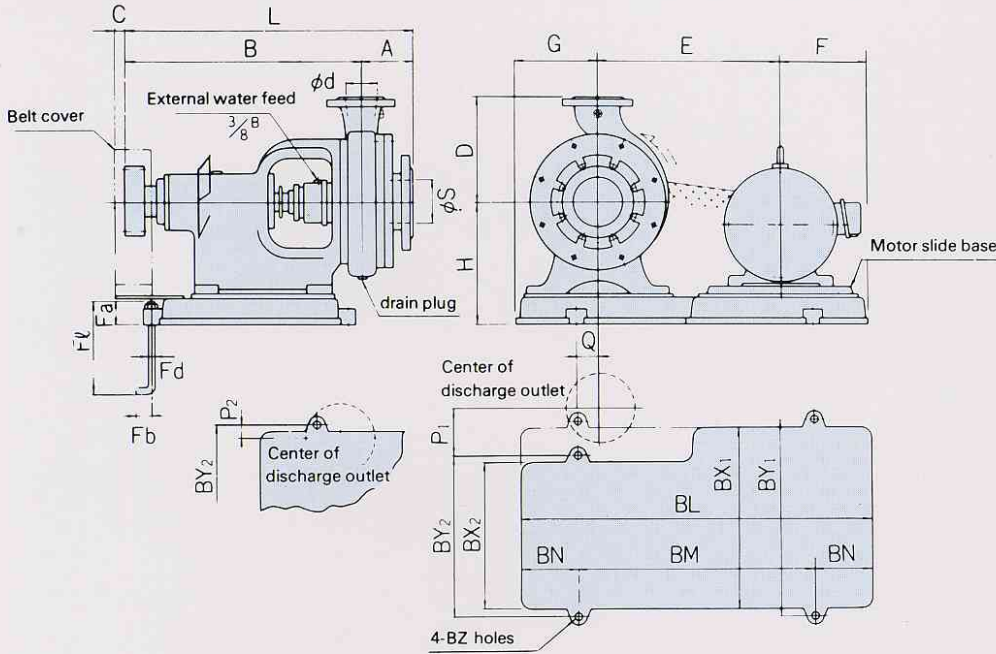

Unit: mm

Size $\phi S \times \phi d$	g	e	F	t	n	h
40	85	105	140	18	4	19
50	100	120	155	20	4	19
65	120	140	175	22	4	19
80	130	150	185	22	8	19
100	155	175	210	24	8	19
125	185	210	250	24	8	24
150	215	240	280	26	8	24
200	265	290	330	26	12	24

- Note:
1. The pump must never be allowed to rotate in reverse. Confirm in test operation of motor only that rotation direction is correct.
 2. Motor indicated is for a T.E.F.C type.

Unit: mm

Size $\phi S \times \phi d$	Model	Motor output kW	Pump													Base							Anchor bolt				Weight exp. motor (Mass) kg
			A	B	C	D	E	F	G	H	L	P ₁	P ₂	Q	BL	BM	BN	BX1	BX2	BY1	BY2	BZ	Fd	Fa	Fb	F ℓ	
50×40	50× 40SALH	2.2~7.5	105	540	40	225	355	185	180	275	645	15	—	50	720	460	130	495	495	525	525	15	M12	55	50	250	155
65×50	65× 50SALH	2.2~7.5	110	545	40	280	355	185	180	275	655	25	—	50	720	460	130	495	495	525	525	15	M12	55	50	250	165
	65× 50SALH	11 ~22	110	545	40	280	500	240	190	295	655	20	—	40	930	630	150	570	445	600	475	19	M16	70	63	315	190
80×65	80× 65SALH	2.2~7.5	120	550	40	280	355	185	180	275	670	30	—	50	720	460	130	495	495	525	525	15	M12	55	50	250	175
	80× 65SALH	11 ~22	120	550	40	280	500	240	190	295	670	25	—	40	930	630	150	570	445	600	475	19	M16	70	63	315	200
125×100	125× 100SALH	2.2~7.5	150	565	40	280	355	185	180	275	715	45	—	50	720	460	130	495	495	525	525	15	M12	55	50	250	175
	125× 100SALH	11 ~22	150	565	40	280	500	240	190	295	715	40	—	40	930	630	150	570	445	600	475	19	M16	70	63	315	200
	125× 100SALJ	5.5~15	155	695	40	315	450	220	230	370	850	45	—	70	900	580	160	605	605	635	635	19	M16	70	63	315	320
	125× 100SALJ	18.5~37	155	695	40	315	630	300	230	390	850	—	30	50	1160	800	180	620	620	660	660	24	M20	85	80	400	335
150×125	150× 125SALJ	5.5~15	180	710	40	335	450	220	230	370	890	60	—	70	900	580	160	605	605	635	635	19	M16	70	63	315	390
	150× 125SALJ	18.5~37	180	710	40	335	630	300	230	390	890	—	15	50	1160	800	180	620	620	660	660	24	M20	85	80	400	395
200×150	200× 150SALJ	15 ~22	220	895	40	400	680	280	290	460	1115	120	—	90	1250	850	200	690	690	730	730	24	M20	85	80	400	630
	200× 150SALJ	37 ~75	220	895	40	400	830	380	290	515	1115	100	—	40	1500	1000	250	745	630	785	670	24	M20	85	80	400	685

SAL QT TYPE SELF-PRIMING TANK (Optional)

Installing a self-priming tank, if your SAL pump will be used for vertical, upward suction, will make it possible for you to use the pump for the following applications:

- 1 Install where a general-purpose pump with foot valve is being used. There are many cases of problems arising with a foot valve pump because the valve does not operate correctly, breaks down or causes wear of the pump body.
- 2 Install where a self-priming pump is being used. There are many cases of problems arising due to inefficiency caused by the length of time it takes for priming, malfunction of the check valve on the suction side and wear of the pump body.
- 3 Install where a submersible pump is being used. There are many cases of problems arising from frequent breakdown of the mechanical seal due to dirt and sand, and extreme wear of the pump body.
- 4 Install where a vertical shaft pump is being used. There are many cases of problems arising from wear of the submersible vertical shaft bearing, and the frequent necessity of inspection for repair.

● Principles of Self-Priming: Pumping by means of siphon action

Once the pipes are filled with water (a variety of methods can be used to do this) pumping will be sustained naturally. When the water in a section of piping begins to drop, a vacuum is created at the upper end of the pipe. The atmospheric pressure on the surface of the water in the water tank forces water in the tank up into the pipe so that it is once again full of water. (In a vacuum, atmospheric pressure has enough power to push water up 10 meters.) This is why pumping is sustained when the pipes are full.

If the pipe that is in the water tank is punctured, air will enter through the hole making siphoning impossible and forcing pumping to stop.

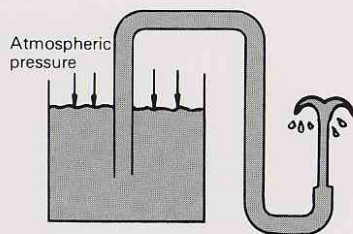

● How to Use the Self-Priming Tank

- 1 Open the air release valve (a) and the feed-water valve (b) and fill the tank with water.
- 2 After the tank has been filled to the point where water overflows from the top of the suction pipe, close valves (a) and (b) and start the pump.
- 3 As the water in the tank is sucked up by the pump, its level will gradually drop and the pressure level in the tank will also drop. However, once pressure has dropped to a certain point, the same siphon principle operates. The water in the water tank on the suction side is pushed by atmospheric pressure into the tank.
- 4 Therefore, when a pump is operated with a self-priming tank there is no need for a foot valve. When the liquid pump contains slurry, the foot valve seat is often worn to the point where it no longer functions and it becomes impossible to operate the pump. With an EBARA Self-priming Tank, however, this sort of trouble will never arise.

- 5 Even when the pump is stopped, all water in the tank will not drain which means it is possible to start the next pump operation without any preparation. Note, however, that if the tank is punctured or suction piping is damaged, self-priming will no longer be possible and the pump will not be able to function.

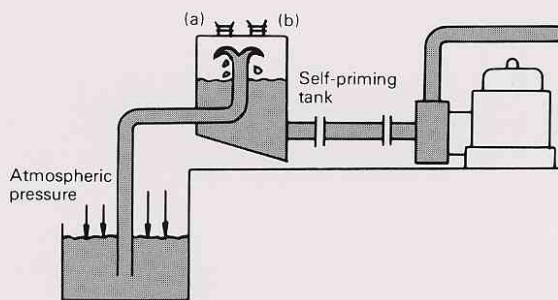

Model and Specifications

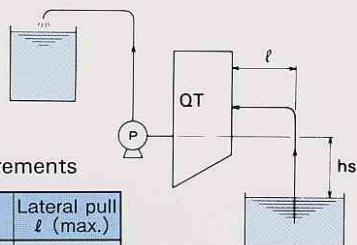

● Tank model and piping requirements

Pump	Tank Model	Head h_s (max.)	Lateral pull l (max.)
40 X 32SAL	QT-1	3m	2m
50 X 40SAL	QT-2	3m	2m
65 X 50SAL	QT-3	3m	2m
80 X 65SAL	QT-4	2.5m	2m
125 X 100SAL	QT-5	2.5m	2m
150 X 125SAL	QT-6	2.0m	2m
200 X 150SAL	QT-7	2.0m	2m

Water (up to 30°C)

- When specific gravity exceeds $\gamma = 1$, adjust h_s according to chart below.

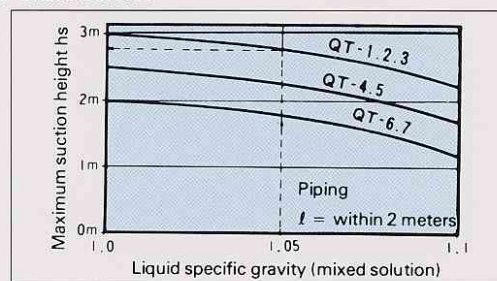

- Pressure: $-1 \sim +0.5 \text{ kgf/cm}^2$ $\{-0.0981 \sim +0.049 \text{ MPa}\}$
- Material: Carbon steel, SUS304L
- Flange: JIS 10 kgf/cm²

Standard Accessories

Air release valve	1
Funnel, with valve	1 set
Anchor bolts	1 set

SAL QT SELF-PRIMING TANK

Dimensions

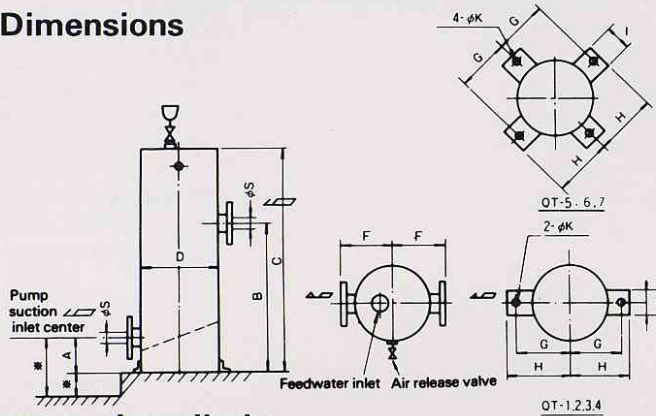

Unit: mm

Model	φS	A	B	C	D	F	G	H	I	K	Weight (Mass) Kg
QT-1	40	100	570	770	217	150	130	144	40	12	27
QT-2	50	120	540	780	268	180	155	174	40	12	40
QT-3	65	120	480	780	319	220	185	205	45	15	53
QT-4	80	120	495	850	356	240	200	223	45	15	63
QT-5	125	160	630	1200	508	350	295	319	65	15	188
QT-6	150	210	980	1670	562	400	320	346	65	19	210
QT-7	200	280	580	1600	812	550	450	481	75	24	320

Note: Dimensions marked with asterisk(*) must match pump dimensions.

Notes on Installation

- One self-priming tank should be installed for each pump.
- Pump suction piping:
 1. Connect self-priming tank and pump with no more than two meters of straight piping. Avoid use of elbows as much as possible.
 2. Never allow air in the suction side since pressure will drop.
- Pump discharge piping:
 1. Discharge piping should be higher than top of tank.
 2. Total discharge piping length should be as shown in table below.

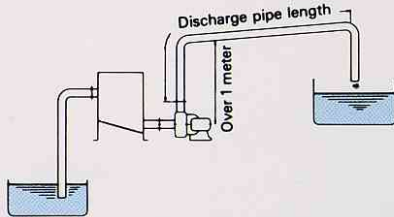

Pump size	Discharge pipe length × dia.
40 × 32SAL	18m × 1 1/4 B
50 × 40SAL	18m × 1 1/2 B
65 × 50SAL	13m × 2B
80 × 65SAL	10m × 2 1/2 B
125 × 100SAL	12m × 4B
150 × 125SAL	17m × 5B
200 × 150SAL	24m × 6B

CONVERSION OF SI UNIT
1 kgf/cm² = 0.0980665 MPa

3. The end of the discharge piping should be higher than the suction water level.

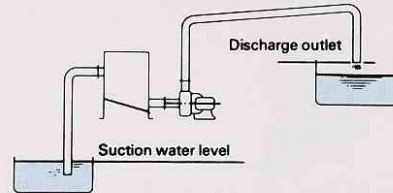

4. Do not use a check valve. Install so that there will not be a reverse flow at the end of the discharge piping.

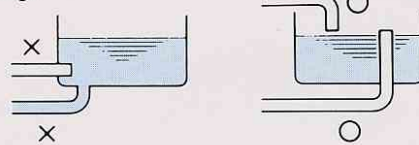

5. When a pump is not operated for extended periods, or when it is a type that does not use external feedwater, add water to the tank occasionally.

* All specifications subject to change without notice.
In this catalog, the particulars in { } are in accordance with the International System of Units (SI) and given for reference only.

DISTRIBUTED BY

EBARA CORPORATION

Standard Products Marketing & Sales Office

Phone: 81-3-5714-6111 Fax: 81-3-5714-6088

Website: <http://www.ebara.co.jp>

Ebara Engineering Singapore Pte. Ltd. (Singapore)

Phone: 65-862-3536 Fax: 65-861-0589

Ebara Middle East Branch Office (U.A.E.)

Phone: 971-4-838889 Fax: 971-4-835307